

Vehicle-Scale Infinite-Axis Pellet Extrusion (FGF) Manufacturing System

APPLICATIONS

- Vehicle Prototyping
- Large-Scale Infrastructure Components
- Emergency Fabrication for Crisis Management
- Boat Hull & Marine Mold Fabrication
- Housing Construction
- Distributed/Rural Manufacturing
- Furniture & Interior Structure Production

TECHNICAL FEATURES

- Build Volume: **1524 × 1800 × ∞¹mm**
 - Z-axis via belt
- Feedstock: **Pellet Extrusion (FGF)**
 - Low material cost
 - Beneficial ergonomics
- Nozzle diameter range: 1-5mm
- Extrusion speed: typically 400mm/s see Figure 4
- Deployability: Shipping-container portable; self-fabricating structure
- Cost Efficiency: Designed with minimal precision parts
- Firmware: **Modified Klipper**
 - Any G-code slicer accepted; trigonometric belt transform applied automatically
 - Native diagonal slicing via Kirimoto (free, open-source)
- Primary power: **48V DC, ~2500W**
 - AC input: 120-240V single/dual/three phase (~3000W with conversion loss)
 - Solar and other on-site DC generation supported

SYSTEM LAYOUT

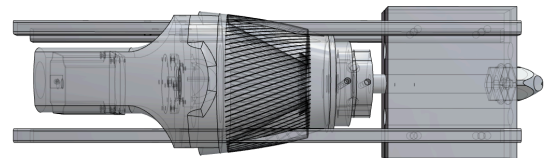
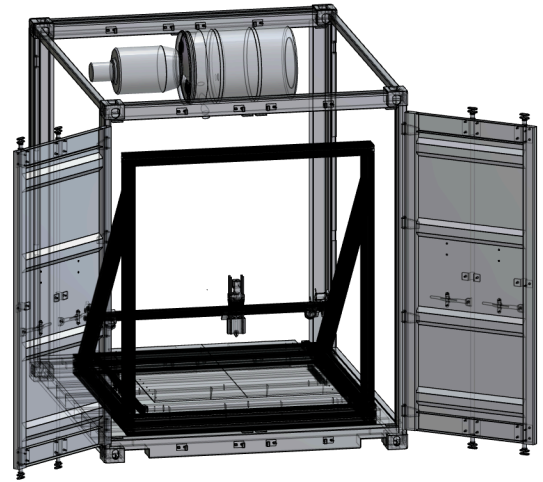

OPERATIONAL SPECIFICATIONS

Characteristics	Condition	Value
Max Flow Rate (Pellet)	2mm Nozzle	Up to 400mm/s
Z-Axis Capacity	Belt Mode	∞ (Continuous)
Footprint	Deployed	Container Class
Positional Tolerance (X)	—	± 0.4mm
Positional Tolerance (Y)	—	± 0.3mm
Positional Tolerance (Z)	—	± 0.5mm

¹Z-axis belt can continue indefinitely until it experiences an opposing force greater than ~600 Newtons.

Power Consumption	48V DC (Primary)	~2500W
Power Consumption	AC Input	~3000W

Full Machine View

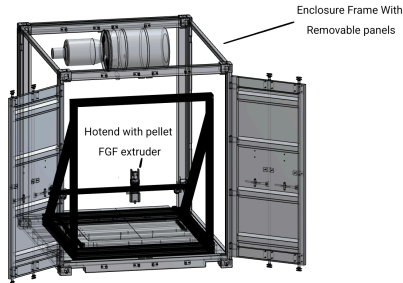

Extruder View

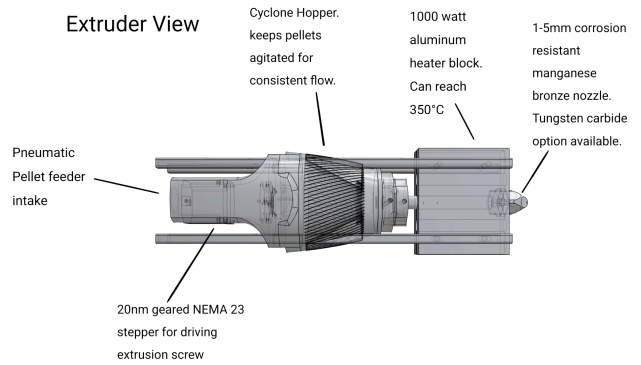

55 gallon pellet reservoir with air compressor for pneumatic feeding

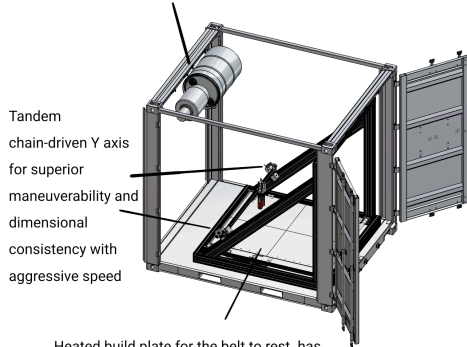

Heated build plate for the belt to rest. has tension adjustment systems for replacing build surface belts

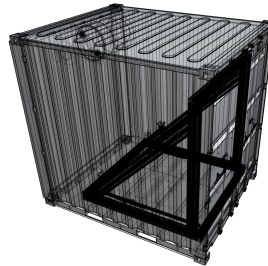

X-Ray View of enclosed operation mode (Note that maximum z-axis size becomes limited in this mode)

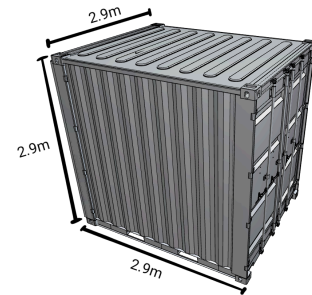

Fully enclosed. IP64 water resistant. compact 10ft shipping form factor (shown). Standard 20ft option available for extra storage.

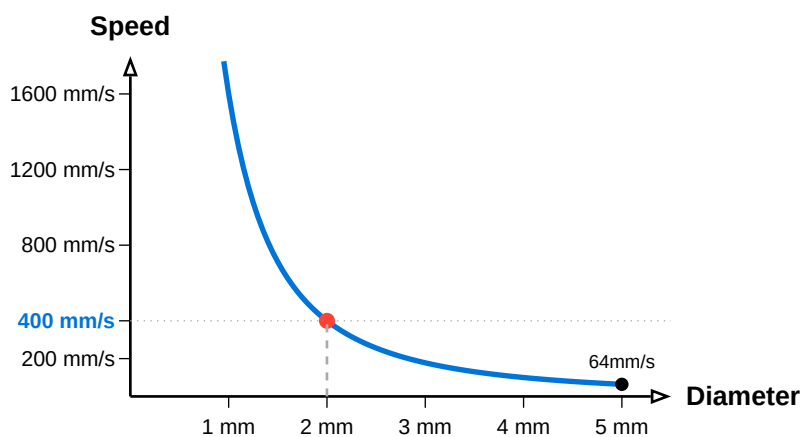

Figure 4: Extrusion Speed vs. Nozzle Diameter²

²2mm achieves up to 400mm/s. Any speed greater than 400mm/s will depend on other machine parameters.

MARKET ANALYSIS & COMPETITIVE LANDSCAPE

FGF = Fused Granulate Fabrication, i.e. 3D printing via pellet resins rather than filament feed CapEx = capital expenditure

Machine	Process	Build Volume	∞ Axis?	Price	Notable Features	vs. HyperPrint	Rural Deployable?	Sources
HyperPrint	pellet-fed FGF	1524 × 1800 × ∞ mm	Yes	\$25k - \$50k new	Container portable; rural deployability; self-fabricating structure; continuous production	Baseline	Yes	ExoBody
Thermwood LSAM	pellet-fed FGF + milling	3048 × 1524 × ≤ 3048mm	No	≈ \$400k+	High throughput (>90.7/hr); integral milling	Much higher CapEx; Not portable	No	thermwood
Cincinnati BAAM	pellet-fed FGF	3556 × 1651 × 2489mm	No	Used: ≈ \$250k	High deposition; Industry incumbent	Enormous CapEx; HyperPrint wins on price + belt	No	aniwaa asme
Ingersoll MasterPrint	pellet-fed FGF + milling	18,288 × 6706 × 3048mm	No	Quote Only ³	Hybrid capabilities (Print + Mill)	Large enterprise scale; not for distributed use	Partial ⁴	camozzi
Titan Atlas 2.5	pellet-fed FGF	1070 × 1070 × 1118mm	No	Used: ≈ \$80k	Mid-industrial hybrid platform	Smaller envelope; no infinite axis	No	revelationmachinery
JuggerBot P3-44	pellet-fed FGF	914 × 1219 × 1219mm	No	\$275k - \$325k	High temp thermoplastics; 6.8kg/hr, heated chamber	Higher cost; smaller volume than HyperPrint	No	all3dp 3dprintingindustry
BigRep PRO	filament FDM	1020 × 970 × 985mm	No	≈ \$198k	Enclosed chamber; Precision FDM	Filament is expensive; finite volume	No	bigrep
Builder Extreme 1500 PRO	filament FDM	1100 × 500 × 820mm	No	≈ \$34.9k	Office-friendly large format	Filament is expensive; finite volume	Partial ⁵	builder3dprinters
Modix BIG-180X	filament FDM	1800 × 600 × 660mm	No	≈ \$19k	Great volume per dollar; Kit assembly required	Filament is expensive; finite volume; not preassembled	Partial ⁶	modix3d
Blackbelt 3D	filament FDM	340 × 340 × ∞ mm	Yes	≈ \$14.6k	Continuous production	Filament is expensive; Much smaller scale	Yes	aniwaa

³likely ≥ 1 million USD

⁴Portability features available via specialized units

⁵No ruggedized outdoor spec on website. Packaged form factor is not containerized. Domestic power hookup is feasible (120-240V). Manufacturer notes inbuilt transportation wheels.

⁶Power requirements are not solar-friendly. Deployable with on-site electric service. No containerization.